



**EZ-ACCESS<sup>®</sup>**  
**Modular Ramp Systems**



Shown with optional powder coated handrails



**Any home,  
any time**  
you need access.

# Modular Ramp System

Designed to address the accessibility needs of the residential market, the EZ-ACCESS® Modular Ramp system is an excellent choice when accessibility needs extend beyond the scope of a portable ramp. The efficient design uses less hardware and no pre-assembly is required.

**EZ-ACCESS**  
**Modular Ramps**  
**offer quick and**  
**convenient**  
**installation and**  
**removal.**

Made in the USA.  
For residential use only.



Shown with optional powder coated handrails

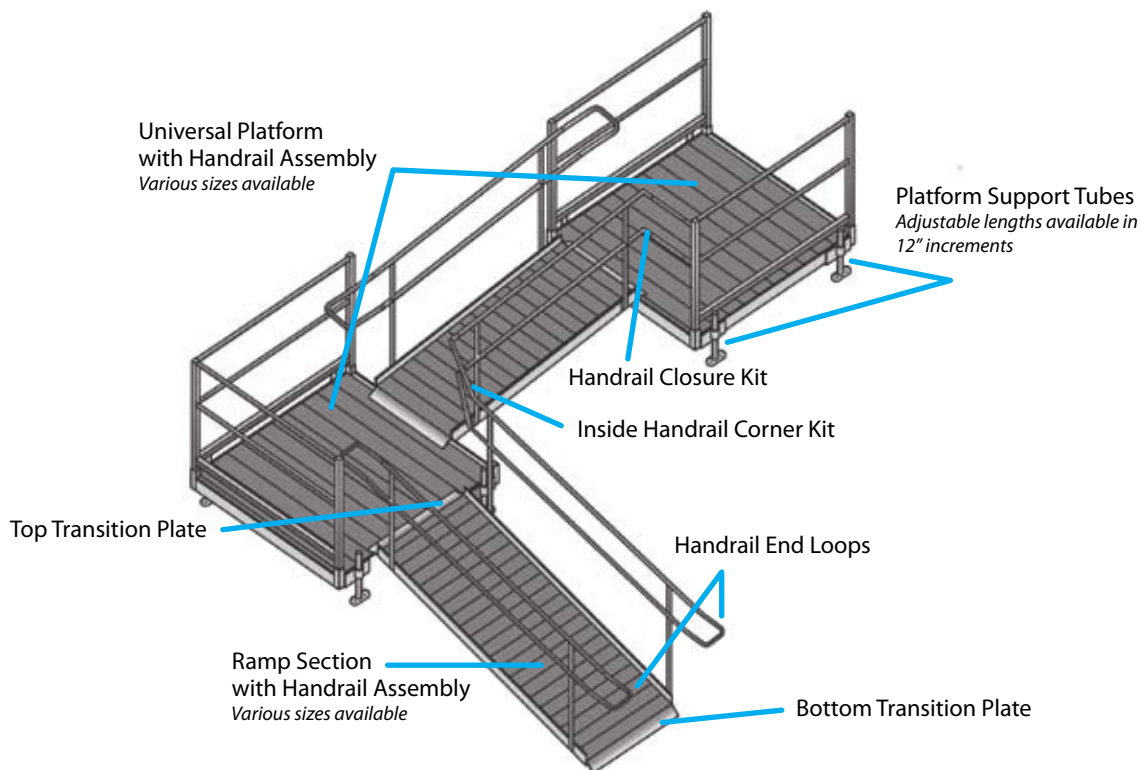

# It's how they're put together that sets them apart.



- ✓ A 24-foot system can be installed, including handrails, in less than 30 minutes
- ✓ Handrails feature a brushed, architectural finish (optional powder coated finish is also available)
- ✓ Universal components and platforms ensure fewer parts
- ✓ Made of durable, lightweight aluminum that does not rust, rot, or decay
- ✓ Ramps, platforms, and handrails require minimal assembly
- ✓ No anchoring into concrete footings or pads is required
- ✓ Architecturally designed for a clean, modern appearance
- ✓ Low maintenance
- ✓ Can be easily expanded, reconfigured, or moved
- ✓ Permanent non-skid surface
- ✓ Sides are finished and flush; no hazardous nuts or bolts protruding into usable ramp area
- ✓ 850 pound weight capacity
- ✓ 36" width (standard)
- ✓ 48" and other custom widths available

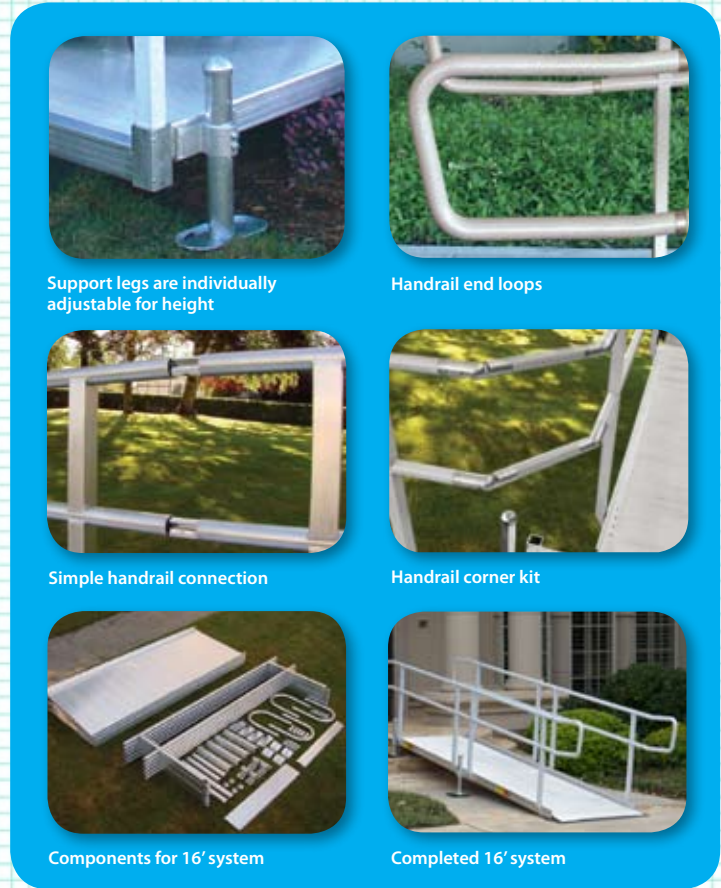

Support legs are individually adjustable for height

Handrail end loops

Simple handrail connection

Handrail corner kit

Components for 16' system

Completed 16' system

## Sample Ramp Configurations

Use the following examples to establish your desired ramp configuration (Section 1 reflects basic configurations, while Section 2 features sample combined configurations). Please keep in mind that we can accommodate virtually any ramp need.

### Section 1 Basic Configurations

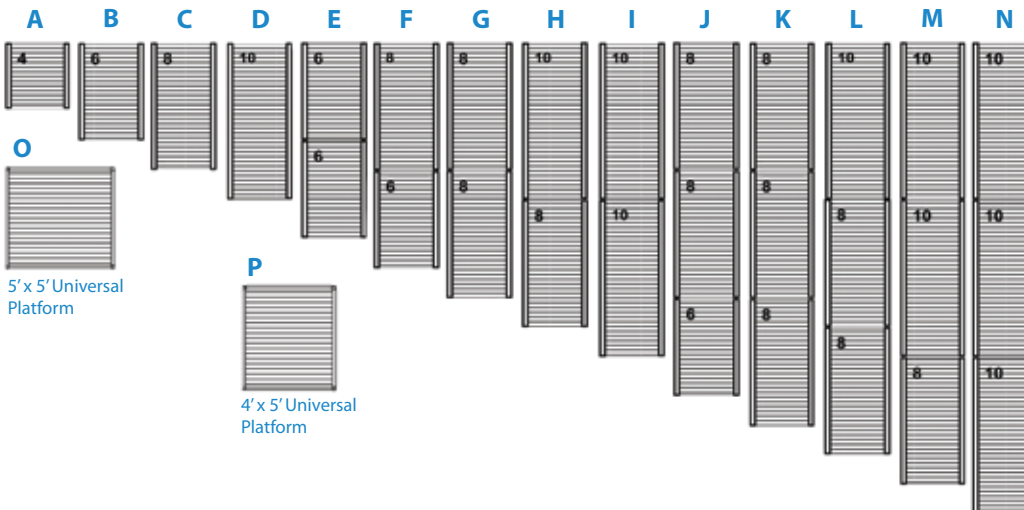

### Section 2 Sample Combinations

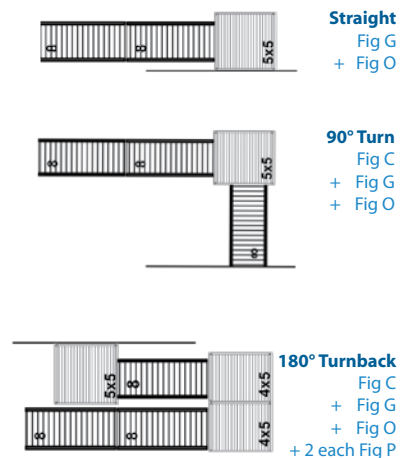

# Think American. Think Green. Think EZ-ACCESS!

- We are proud to offer ramps that are American made, by Americans — sustaining American jobs.
- Our modular and portable ramps are made of aluminum. Unlike wood that may be treated with toxic chemicals or steel that is subject to rust and decay, aluminum has excellent corrosion resistance and is environmentally friendly.
- Additionally, not only is aluminum recyclable in the traditional way, EZ-ACCESS Modular ramps can be easily expanded, moved, or reconfigured if needed, giving them an even longer life cycle.

Distributed in Canada by Handicare  
1-800-514-7061 • Fax 416-739-6622  
[www.handicare.ca](http://www.handicare.ca)



Authorized EZ-ACCESS Dealer



**1-800-451-1903 • Fax 1-800-630-2350**  
**[www.ezaccess.com](http://www.ezaccess.com)**

