



## USER MANUAL

### Bathe with the help of BathLyft

SolutionBased is grateful that you entrusted us with your safety and well-being. The BathLyft will make your life easier by assisting you in and out of the bathtub. It is also easily transportable and can be used at home or on the go.

Statistics show that 80% of elderly falls occur in the bathroom. SolutionBased would like to address this issue. The BathLyft alleviates the fear of falling and creates a secure environment to enjoy a soothing bath.

Bathing aids such as BathLyft assist users with their daily hygiene. These aids compensate, in whole or in part, for restricted or lost physical functions. The goal of using such aids is to enable their users to be independent and to give them more privacy.

The BathLyft can be used to lower and raise a user in the bath. It is recommended that the physical mobility of one's upper and or lower extremities is significantly reduced, making it difficult to get in or out of the bath. In these cases, the use of BathLyft is a great help.

#### Find it easy...

Description & Features	1	Assembly & Instalation	5	Technical Data BathLyft	9
Components and Parts	2	How to Use	6	Warranty	10
Operating Instructions	3	Troubleshooting	7	Disassembling	10
Charging Instructions	4	Maintenance	7		
Remote	4	Technical Data BathLyft	8		

## Description

In essence, the BathLyft is an electric submersible bath chair that attaches to the bottom of your tub with six suction cups. Simply sit on the tub flap extension and slide onto the BathLyft. Once secured, with the press and hold of a button, it gradually descends into the tub so you can safely take a bath independently and without worry. For additional safety, intelligent logic in the handset remote prevents lowering the BathLyft if there is not enough power to raise it back up. When finished, press and hold the up button, and it will gradually bring you back up to the desired height making it a breeze to get out of the tub.



## Features

- 300 lbs. weight capacity
- 6 self release suction cups
- High backrest
- Tool-Less Assembly
- Compact, fits into most standard tubs
- Reclines to 53° at lowest position
- Lowers to 2.75 inches
- Total weight 25lb
- Seat Weight 16lb
- Back weight 9lb



## Components and Parts



Please confirm all the above parts are included when you unpack the bath lift. Contact your supplier promptly for assistance if there are any parts missing.

# Operating Instructions

## Precautions

1. Before your first use, carefully read and follow the instructions.
2. Charge the handset before first use and or if the BathLyft has not been used for more than one month.
3. Ensure that the user does not exceed the limitations stated in the Technical Data.
4. Prior to each use, check all the parts for damage. Do not use if any parts are damaged
5. Ensure lift is not submerged in water with excessive amounts of bath oils, bath salts and other bath supplies.
6. User should always exercise caution when using the bath lift by moving slowly on and off the bath lift.
7. Only use the provided handset with the bath lift.

## Warnings

1. Do NOT overload.
2. Do NOT stand on the bath lift.
3. Do NOT face back rest when using.
4. Do NOT install on a steeper surface than a 5-degree grade.
5. Do NOT use if parts are damaged.
6. Do NOT use for anything besides intended purpose.
7. Do NOT let children use without adult supervision.
8. Do NOT obstruct moving parts with your body or any other object while in use.
9. Do NOT place objects in or near the scissor rods(such as toothbrush, razor, etc).
10. Do NOT attempt to repair equipment.
11. Do NOT place or store handset near a heat source.

**Make sure that the battery is fully charged before use! The voltage rating on the charging unit must be compatible with the voltage of your power supply. For example, 220V- 240V in Europe, and 110V in the USA.**

## The Charger

1. Only use the included charger or the replacement charger provided by SB.
2. Do not charge near water, heat or any other source that could harm the battery.
3. The charging LED indicator is green when connected to the wall outlet and has current.
4. Do NOT use charger for any other purposes other than charging the handset.



## Charging Instructions

1. Disconnect the handset from the bath lift.
2. Ensure the handset, connectors and the charger are dry.
3. Plug charger into the correct wall outlet.
4. Connect the handset's male plug to charger's female plug and ensure the connection is secure.
5. The charger LED indicator is red while charging and green when the battery is fully charged. Typically takes 2-3 hours.
6. When the charging is complete, unplug charger from the wall and disconnect the remote from the charger.



## Remote

1. Check remote LED before each use.  
Green = Charged  
Blue = Low Battery  
Red = Battery Dead
2. The UP button on the handset will make the bath lift to rise, the DOWN button will make the bath lift to lower, the STOP button will cause the bath lift to stop motion.
3. The red STOP button will make the BathLyft stop moving in case of emergency

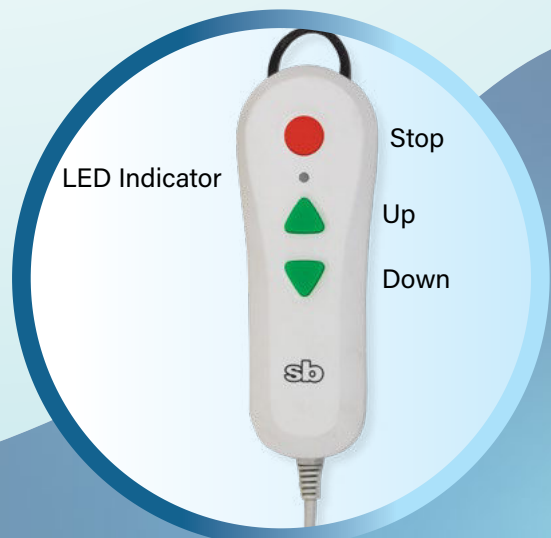

## Assembly & Installation

1

Ensure the six suction cups are secured to the bath lift.



2

Align the backrest hooks with the base guide bars and push the hooks on each side of the backrest to connect them to the base.



3

To ensure the backrest is properly installed, (lift/open) the backrest until the back is at its fully reclined position.



4

Make sure the top clevis of the actuator is connected correctly with the base hook lock.



5



## How to use



Connect the remote into the actuator of the BathLyft.



Place the BathLyft into your bathtub and make sure the backrest is at its fully reclined position.



Use the handset to raise the bath lift until the side flaps are resting on top of the tub walls.



Sit on the side flap and transfer to the center of the seat placing your feet inside the bathtub.



Press and hold the Down button on the remote to lower the Bathlyft into the tub.

Once the lift is at its lowest point, use the down button to adjust the back rest to the desired resting angle (up to degrees).

When done bathing, press and hold the up button to raise the BathLyft back up

## Troubleshooting

Error	Possible Cause	Remedy
Lift does not move or stops repeatedly	<ul style="list-style-type: none"><li>▪ Battery is depleted</li><li>▪ Contacts on hand control are damaged</li><li>▪ Hand control is not connected properly</li><li>▪ Excessive Lifting Load</li></ul>	<ul style="list-style-type: none"><li>▪ Charge battery</li><li>▪ Unplug hand control; wipe contacts with a dry cloth and plug hand control in again</li><li>▪ Check plug type connections</li><li>▪ Reduce lifting load (max load ratings on page x)</li></ul>
Remote does not hold charge	<ul style="list-style-type: none"><li>▪ Charger is damaged or needs more amps.</li><li>▪ Contaminated contacts</li><li>▪ Battery in remote is damaged</li></ul>	<ul style="list-style-type: none"><li>▪ Connect charger to a different outlet or replace charger</li><li>▪ Wipe contacts with dry cloth</li><li>▪ Replace the remote</li></ul>
Hand control does not function correctly	Loose connection between handset and bath lift	Ensure jack plug is fully plugged in

### Important remarks concerning troubleshooting:

1. If the linear actuator becomes disconnected as shown in "Picture 2", manually adjust the linear actuator so it mates correctly as shown in "Picture 4".
2. If troubleshooting does not solve the issue, please contact SolutionBased immediately.

### Maintenance

1. After each use, rinse with warm water. Use a wash cloth or brush to remove excess buildup or grime.
2. Do not use harsh detergents to clean any part of the lift.
3. Only clean the remote while connected to the BathLyft NOT when disconnected or connected to the charger.
4. Ensure the BathLyft is fully dry before storing.
5. Only handwash components of the lift.
6. Do not wash the charger, only wipe with a cloth.



# Technical Data

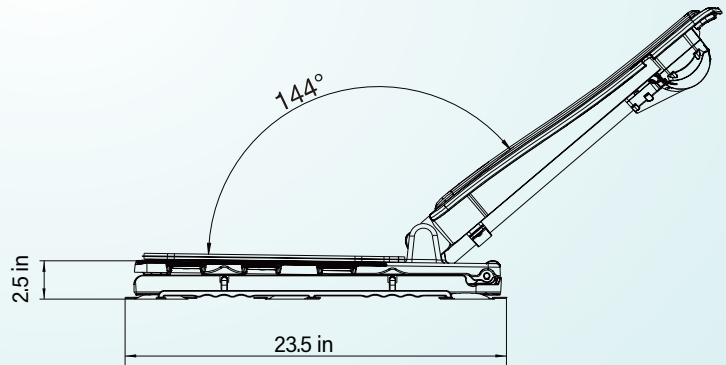
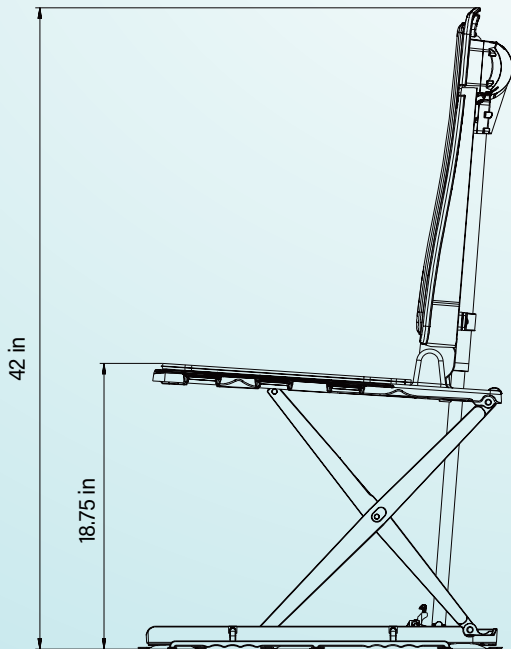
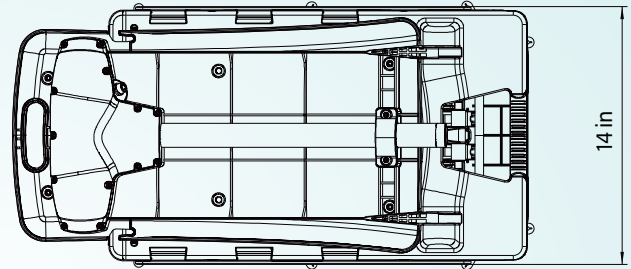
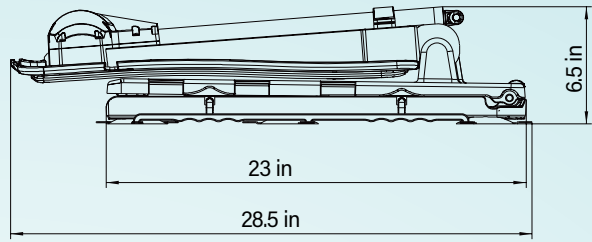
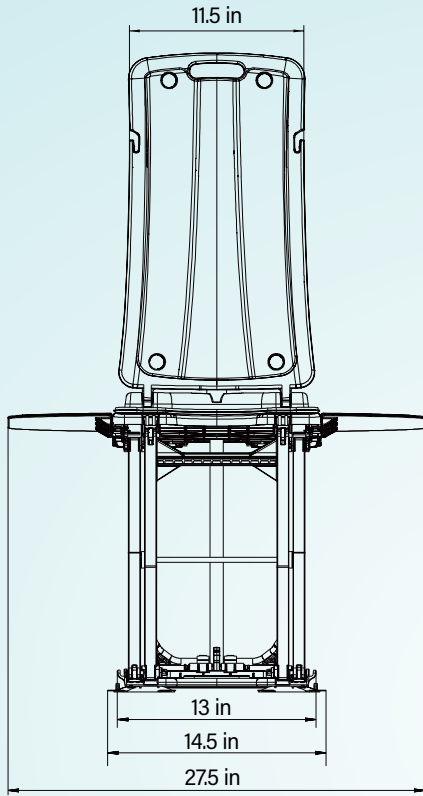

## Technical Data

Overall length (with backrest in a reclined position)	38.8 in
Overall width (seat incl. side flaps)	28.5 in
Width of seat	15.7 in
Depth of seat	16.7 in
Overall length of seat	23.2 in
Sitting height min	3.1 in
Sitting height max	19.2 in
Height of backrest	25.6 in
Width of backrest	13.8 in - 14.2 in
Backrest adjustment	5°-max45°
Width of base plate	12.2 in
Length of base plate	24.1 in
Load capacity max	308.6 lb
Total weight (excl. hand control)	21.2 lb
Total weight (incl. hand control)	22.3 lb
Weight of hand control incl. battery	1.1 lb
Weight of drive unit	7.9 lb
Weight of seat unit	13.3 lb
Duration of lifting/lowering movement each	under 231 lb. load, lifting:90s; lowering:50s
Operating voltage	14.8V
Storage battery (lithium-ion)	14.8V/2.2Ah
Automatic shutdown	max. 30min
Power input	16.8V

## Warranty

The warranty for the BathLyft will be in accordance with legal stipulations and regulations valid in different countries. The warranty applies to Commercial and Domestic applications, subject to the conditions stated here. If any part/product develops a manufacturing fault or design fault within the warranty period, replacement parts will be supplied free of charge. The warranty is provided to the first-time purchaser or user in all instances. The warranty is not transferable.

SolutionBased grants a 1 year warranty on frame, actuator, hand control and charger. Suction cups and padding are excluded from the warranty.

Damage due to natural wear or improper handling is excluded from the warranty.  
Damage caused by material or manufacturing

faults will be remedied free of charge by way of replacement or repair. The warranty will become invalid in the event of unauthorized manipulation of any kind. Warranty claims can only be accepted if the device is returned to the supplier in a non-dismantled condition and obtaining a formal return authorization. Any further claims are excluded unless in the case of contradicting mandatory national stipulations. SolutionBased is not to be held liable for any indirect or direct damage or consequential damage, loss, or expenses in connection with the use or inability to use the device for a specific purpose. Tacit agreements concerning the use or suitability for a specific purpose are expressly excluded.

**If you are returning a Bathlyft please disassemble the BathLyft carefully for repackaging.**

Unplug the remote and fold in the side flaps. Fold the backrest down.

Place a towel between the back rest and the seat base.  
Next, place a house hold screw driver between the towel and the back rest towards the rear of the seat.

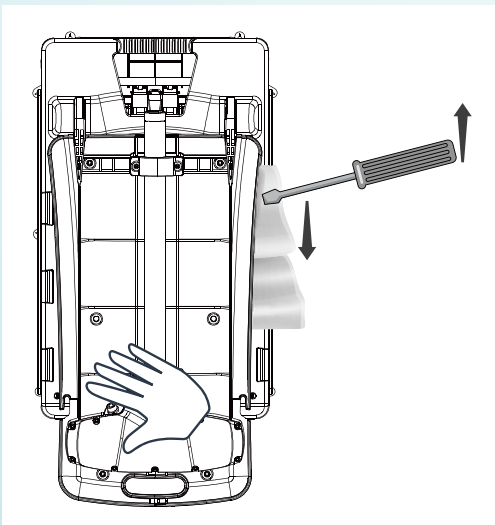

Hold the back rest down at the front end and PULL the handle of the screw driver up pushing the tip of the screw driver against the seat base for leverage. This will pop off the backrest from the seat base.

A thick bath towel will keep the seat from getting damaged from the screw driver. Do one side at a time.



Disassembling the  
Bathlyft Video



 **bathLyft** *By* **sb**

12405 Montague Street Pacoima, CA 91331  
800.337.6660 | [www.bathlyft.com](http://www.bathlyft.com) | [www.sb.care](http://www.sb.care)