

# Handicare **1000** stairlift

FOR STRAIGHT STAIRCASES



## Hidden gear rack for a streamlined look and high capacity option

Many people choose the 1000 due to its unobtrusive look with the anodized aluminum rail and hidden gear rack. Available with standard 350 lb capacity, you can also upgrade to a 440 lb capacity, making this a great choice if you need the extra lifting strength. This model offers a variety of additional options including a powered seat swivel, powered folding footrest, powered or manual hinged rail for the bottom landing, and a Perch seat for semi-standing use. The Handicare 1000 from Savaria is also an ideal choice for outdoor applications depending on your local climate.



Sleek and unobtrusive aluminum rail looks great on your stairs. Add powered options, a higher capacity or outdoor package with this robust stairlift.

 **savaria**

# Handicare 1000 | Straight Stairlift



The 1000 outdoor unit is UV- and weather-protected and features slate gray fabric. Suitable for moderate climates.



Choose the Perch seat, that allows you to ride in a semi-standing position, if you have limited knee or hip flexibility.



**Other Options**  
Powered seat swivel, power folding footrest, manual or power hinged rail, body harness.

## Specifications

<b>Applications</b>	Residential, commercial <sup>1</sup> indoor, outdoor <sup>2</sup>
<b>Capacity</b>	350 lb (159 kg), optional 440 lb (200 kg), 300 lb (136 kg) for Perch seat
<b>Nominal Speed</b>	13 ft/min (0.07 m/s)
<b>Drive/Motor</b>	Rack and pinion, 1/3 HP, 24 VDC power that charges on standard household power
<b>Fold-up Depth</b>	15.1" (384 mm), 12" (305 mm) for Perch seat
<b>Fold-out Depth</b>	25.6" (651 mm), 27.1" (689 mm) for Perch seat
<b>Range of Incline</b>	21° to 56° (27° to 52° with hinged rail)
<b>Warranty</b>	24 months parts and limited lifetime on rail and powertrain <sup>3</sup>
<b>Standard Features</b>	Wipe-clean upholstery, retractable seat belt, emergency stop button, obstruction sensors, non-slip footrest, charging at top and bottom, battery powered for emergency use during power failure, two remote controls, armrest control, keyed switch to prevent unauthorized use

<sup>1</sup>varies by region, not available in Canada, <sup>2</sup>varies by climate and proximity to salt water, <sup>3</sup>see dealer for complete details

## Dimensions

### Smart and Outdoor Seats

- A** 3" (75 mm)
- B** 14.25" (360 mm)
- C** 18.125" (465 mm)
- D** 17.875" (455 mm)
- E** 18.25–21.25" (465–540 mm)
- F** 2.75" (70 mm)

### Perch Seat

- A** 3" (75 mm)
- B** 12.625" (247 mm)
- C** 18.125" (465 mm)
- D** 17.875" (455 mm)
- E** 26.5–34.5" (675–875 mm)
- F** 2.75" (70 mm)

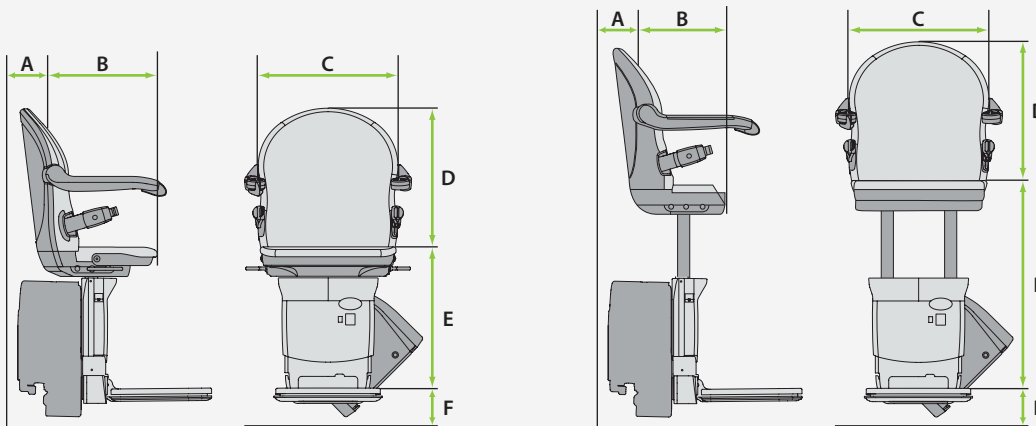

### Optional Fabric Colors

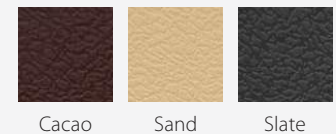

1.888.333.5023 [savariahomeaccess.com](http://savariahomeaccess.com)

Authorized Dealer:

Savaria is a global leader in accessibility. We design and manufacture reliable commercial accessibility elevators, home elevators, wheelchair lifts and Handicare stairlifts. All of our products are made with the goal of helping people move – whether that's to overcome mobility challenges or to simply make life easier.